

DEIMOS ULTRA BT A600 UL

RANGE

Electromechanical automation for rack sliding gates up to 1,300Lbs and 75 Feet

DEIMOS ULTRA BT A600 UL

R925292 00003 - with 1 mitto transmitter

KR925228 00003 - with 1 mitto + Safety Photo Eye

P925186 00002 - Deimos Only



SMART TECHNOLOGY

Magnetic limit switch control at the end cycle.

Incorporated two-channel rolling code radio receiver.

Self contained control panel unit with self-learning and self-diagnostic functions.

Control unit compatible with the EElink protocol and Solor compatible with "Ecosol" solar kit

SAFE USE

- This version powered at 24V has been specifically designed for simpler and faster installation in compliance with the latest UL 325-2016 safety standards.
- The 24V electrical motor guarantees maximum accuracy in torque and speed control. Suitable for intensive gate use, even in industrial installations. Optional battery back-up can be fitted within operator casing. These operators are all "Ecosol" solar compatible
- Contains obstruction sensing device, the operator reverses motion and prevents damage to people and vehicles in the event of contact.



TECHNICAL FEATURES

Control panel	Merak UL
Reversible/irreversible operator	irreversible
Power supply	120 V 60 Hz single-phase
Absorbed power	0.1 hp (70 W)
Thermal protection	integrated in the control unit
Leaf speed	7.9 ips (12 m/min)
Output rotational speed	79 rpm
Pinion pitch	4 mm (14 teeth)
Impact reaction	electronic torque limiter
Limit switches	magnetic
Manual release	lever-operated with personal key
Operating cycle	intensive use
Environmental conditions	from -4F(-20C) to 122F (50C)
Degree of protection	IP44
Operator weight	17.3 lbs
Dimensions	see drawing next page



Be ahead

BFT Americas, Inc.
6100 Broken Sound Parkway N.W.
Boca Raton, FL 33487

T: +1 561 995 8155
T: US. 1877 995 8155
info.bft@bft-usa.com
www.bftaccess.com
www.bft-usa.com

DEIMOS ULTRA BT A600 UL

DIMENSIONS

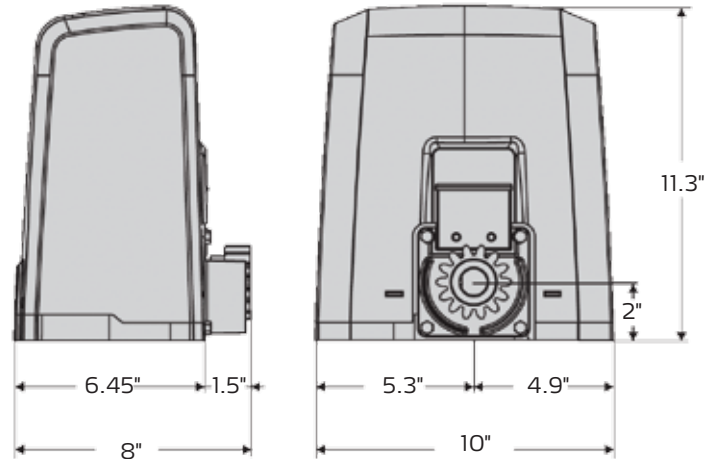

ACCESSORIES



P125035 - SL BAT2
24V DC battery backup system for DEIMOS BT A, ARES BT A, DEIMOS ULTRA BT A, ARES ULTRA BT A, it includes a charger board that activates the batteries when the power is off and charges the batteries when the power is on.



P111468, B EBA
Two serial connection interfaces required for MERAK UL board master and slave connections.



P121024- QB TOUCH
Wireless backlit keypad with 10 channels and 100 combinations



D571053 - CVZ
30x12 4mm pitch galvanised adjustable steel rack 3' 3" length. Sold in boxes of 10.



D221073- CP
22x22 4mm-pitch plastic rack with adjustment slots. 3' 3" length.



CELLBOX PRIME
3G Cellular access control system with 7 day time clock



D111904 Mitto 2 Transmitter:
12V Two channel 433Mhz rolling code remote control



KHLKIT HOMELINK KIT
HomeLink Compatible receiver and transmitter for installing HomeLink with BFT



I700054 10001- KIT CONTROL BOARD
MERAK 600 UL



KED113731H - ECOSOL KIT
Includes Ecosol Interface, solar panel and 15' solar of panel cable, connection harness for easy installation, for running BFT control panels off 24V solar power. Includes two 12V 7.2Ah batteries and circuit board for management of commands to control panel and battery charge management, with built-in Rolling Code 433.92 MHz receiver with 63 stored positions.



Be ahead

BFT Americas, Inc.
6100 Broken Sound Parkway N.W.
Boca Raton, FL 33487

T: +1 561 995 8155
T: US. 1877 995 8155
info.bft@bft-usa.com
www.bftaccess.com
www.bft-usa.com